

M2050

Oil Refilling Instructions



See Video instructions



Connecting and disconnecting Gauges from the Tester body will eventually use up the spare oil capacity and will not allow the tester plunger to travel it's full stroke or give an accurate reading on the Gauge.



Note: It is not necessary to replenish oil if the gauge is a fixed assembly.

To replenish the oil level:

1. Remove the bridge and all accessories.
2. Secure the tester (e.g. in a bench vice or other suitable holding device if on-site) with the coupler in the vertical position.
3. Connect the oil bottle via the quick release coupler.
4. Loosen bottle cap marginally to allow air flow (**fig 1**).
5. Turn the handle anti-clockwise a few turns then using the piston key provided insert this into the groove on the piston. If none of the piston is exposed then please see 'Oil refilling method 2' [document](#). Ensure the piston key outer slot is nearer the piston body (**fig 2**).

If tester is older type with no piston groove then please see 'Oil refill for older testers' [instructions](#).

6. Expel any air out of the system by gently pushing the piston in fully onto the face of the black capsule. Then pull out the piston key and handle until 15mm away from the inside of the slot. This will draw oil from the bottle (**fig 3**).



Ensure not to pull the piston out further than 15mm.

7. Smoothly push the piston back in fully, pull out again and repeat until all the air bubbles are expelled into the bottle. Pull out the piston one more time to 15mm from the face of the capsule to replenish the oil.
8. Tighten the bottle cap and remove the oil bottle.

Fig 1

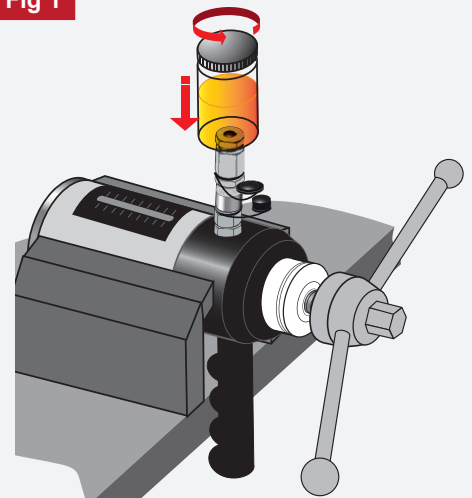

Fig 2

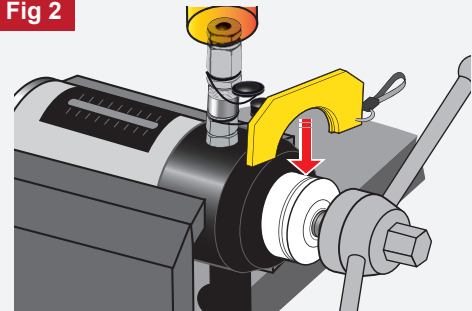
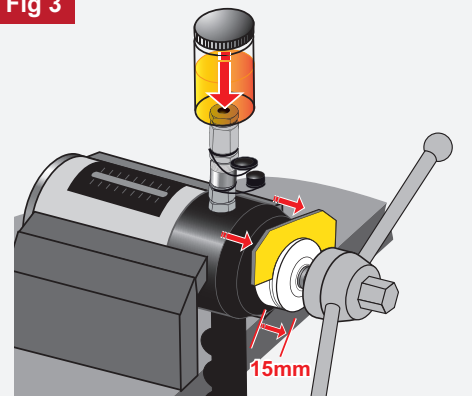

Fig 3



Recommended oil: Light Mineral DTE Type VISCOSITY 32